

## CABLE REELS

### Manual Cable Reels

Sturdy, rugged and built to withstand harsh environments. Minicam manual cable reels are compact, portable and easy to use. The robust powder coated frame houses high tensile strength Kevlar reinforced drain survey cable. Smooth pay-out and re-winding is performance enhanced by the cable layering mechanism and durable heavy duty turning handle. Minicam's specialised crawler connector provides a waterproof sresistenat, and there's a removable drip tray for easy cleaning and maintenance. The reels are available in 3 sizes small 100m, mid-size 250m and large 350m reels of high strength, Kevlar reinforced inspection cable with a weight of 5.5kg per 100m and a breaking strength of 500kg.

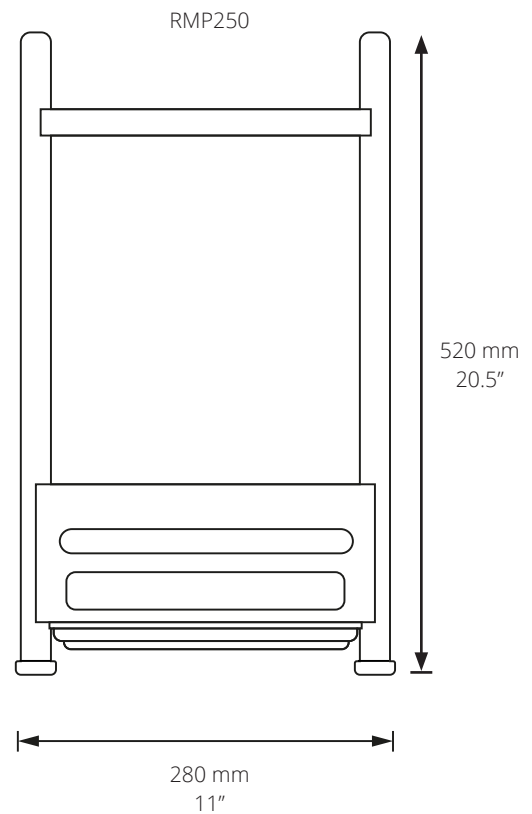
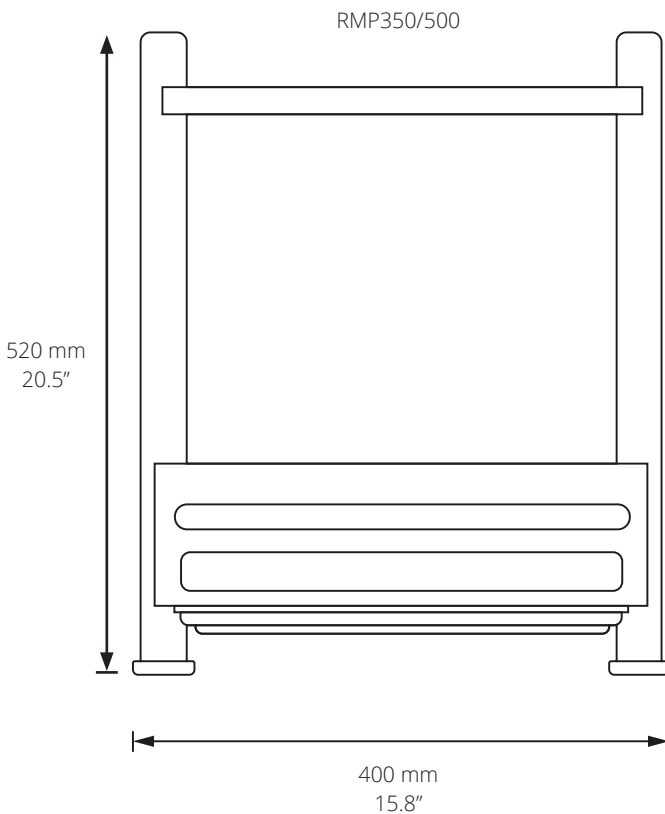

# MINICAM | RMP250/350/500

CABLE REELS

SPECIFICATION

## Technical Data

Product Code	RMP250	RMP350	RMP500
Cable Length	250 m 820 ft	350 m 1150 ft	500 m 1640ft
Dimensions (L x W x H)	530 x 280 x 520 mm 20.8" x 11.0" x 20.5"	530 x 400 x 520 mm 20.8" x 15.8" x 20.5"	530 x 400 x 520 mm 20.8" x 15.8" x 20.5"
Weight	28 kg / 62 lbs	37 kg / 82 lbs	45.25 kg / 100 lbs
Environmental Protection	Splash Proof	Splash Proof	Splash Proof