

## Portable Storage Trolley

Eliminate health hazardous lifting, and time consuming carrying to your remote work site. Engineered to allow for the mobile operation of your Proteus inspection system in difficult to reach areas, such as inside buildings, or other situations a distance away from your vehicle.

The trolley securely holds everything you need to efficiently undertake your pipeline inspection; control unit, reel, battery pack and accessory case. Simply wheel the unit to your location, connect a camera and crawler, and you're up and running in minutes.

The added convenience of Minicam's unique Proteus Power Pack, means there's no need to rely on generator or mains power. The power pack enables pipeline inspection in the most remote locations with up to 5 hours\* inspection time.

*Please Note: Equipment shown on trolley NOT included with PTP01/02  
\*Battery life dependant on operating conditions..*



## Compatibility



## Technical Data

	PTP01	PTP02
Compatibility	RMP100/RMP200	RAP200
Dimensions	650 x 1150 x 750mm	650 x 1150 x 750mm
Weight	9.75kg	9.75kg

# Portable Storage Trolley

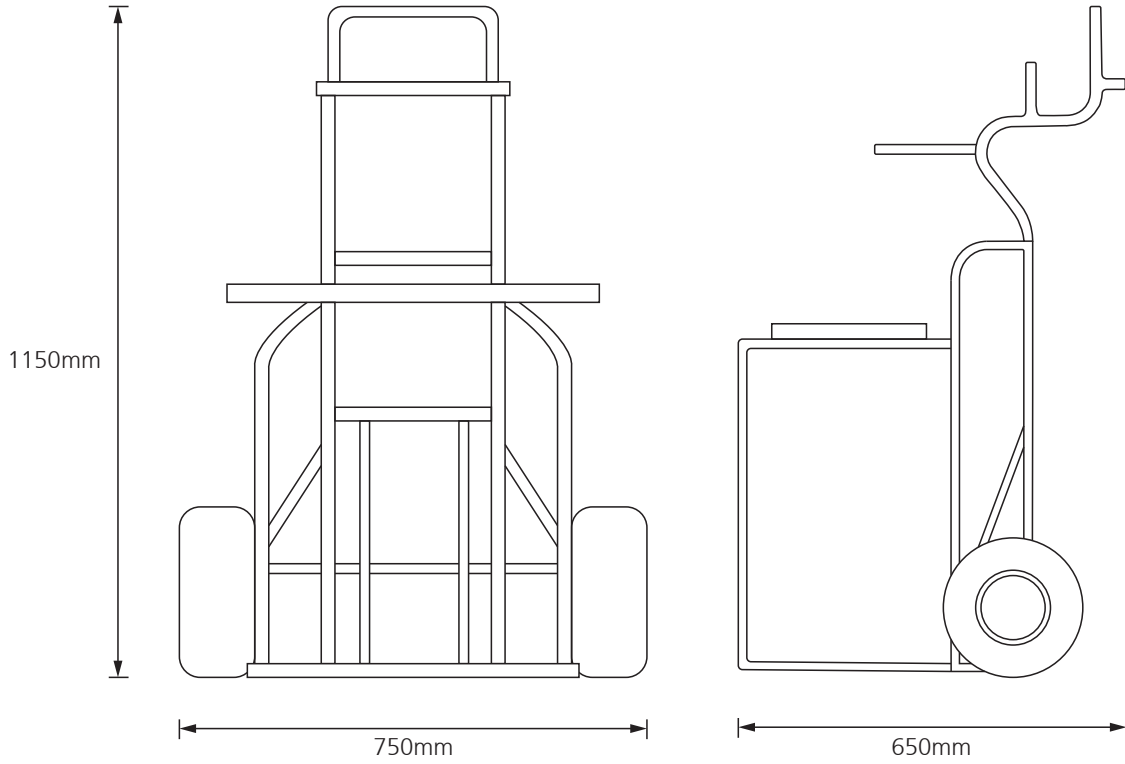

No need to rely on vehicle or mains power. Minicam's unique Proteu sPower Pack enables pipeline inspections in the most remote locations with in excess of 5 hours of inspection time.

112021 © 2022 Minicam



 A Halma company

Minicam Ltd, Unit 33, Ravenscraig Road, Little Hulton, Salford, M38 9PU  
Tel: + 44 (0) 1942 270524 • Email: [info@minicam.co.uk](mailto:info@minicam.co.uk)  
[www.minicamgroup.com](http://www.minicamgroup.com)