

Pan, Rotate, Zoom and Laser Camera

Optical and digital zoom function to allow distant objects to be viewed in much greater detail. Continuous 360° rotation and +/-135° pan. Integral distance sensor and twin lasers to enable accurate pipe diameter, defect and object measurement.



Compatibility



Technical Data

| | |
|---------------------------------|--------------------------|
| Pipe Diameter Measurement Range | 90 - 600mm |
| Aligned Laser Spacing | 30mm |
| Camera Sensor | 800 HTVL |
| Sensitivity | <1.0 Lux |
| Aperture/Field of view | F1.8 - F2.9 / 46° - 4.6° |
| Maximum Illumination Intensity | 12.5k Lux at 150mm |
| Pressure Depth Rating | 1 bar (14.50psi) |
| Dimensions | 155 x 84.5 x 84.5mm |
| Weight | 1148g |

Pan, Rotate, Zoom and Laser Camera

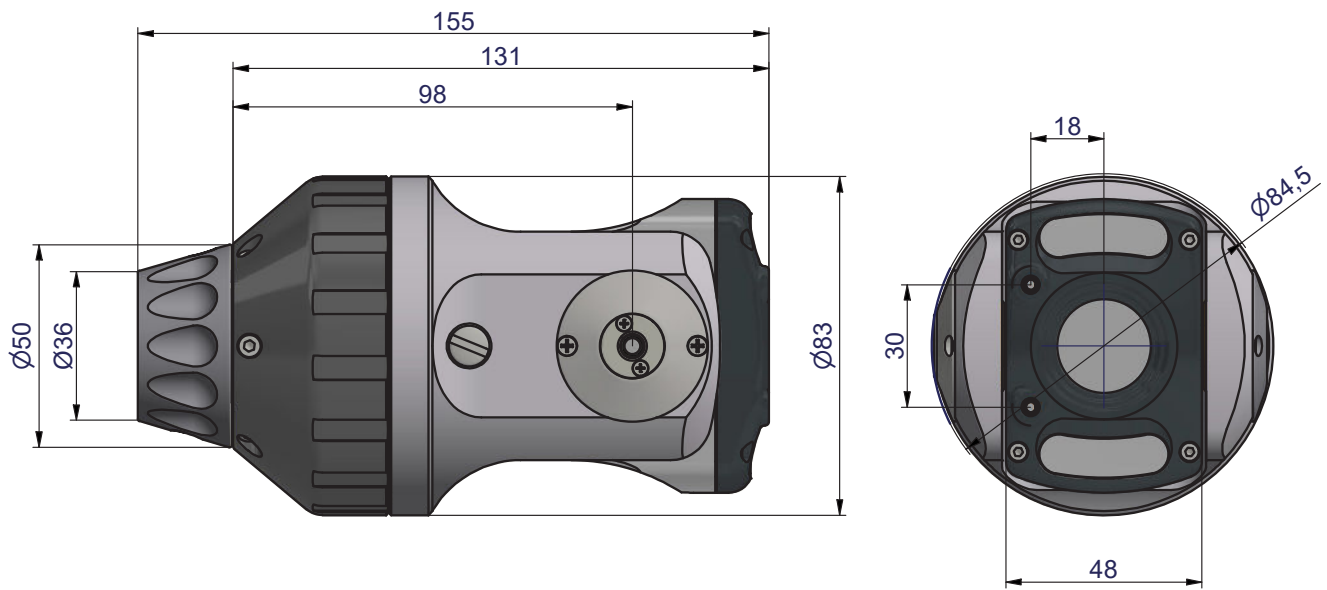

112021 © 2022 Minicam



A Halma company

 **minicam**

Minicam Ltd, Unit 33, Ravenscraig Road, Little Hulton, Salford, M38 9PU
Tel: + 44 (0) 1942 270524 • Email: info@minicam.co.uk
www.minicamgroup.com